

# IOVU-571N ARM-based Panel PC



## Features:

- Nuvoton(Winbond) W90P910CBG 200MHz processor
- low power consumption
- Fanless design for rigorous environments
- 5.7" TFT VGA LCD with resistive touch screen
- Standard peripheral device interface connectors include Ethernet, serial ports, SD, USB and Audio
- Preinstalled Windows® CE5.0 embedded operating system
- Windows® CE5.0 SDK for user application software development
- Default 128MB Flash for OS and user data/programs
- DC input +9V~+28V DC

## Packing List

- 1 x IOVU-571N
- 1 x Utility CD includes application tools, SDK, and technical document.
- 1 x Null modem cable
- 1 x Touch pen
- 1 x Screw kits

## Ordering Information

Part No.	Description
IOVU-571N-CE5/-R10	5.7" VGA fan-less touch panel PC with Winbond W90P910CBG CPU, 128MB SDRAM and built-in Windows® CE5.0 Operating System

## Dimensions (Unit : mm)

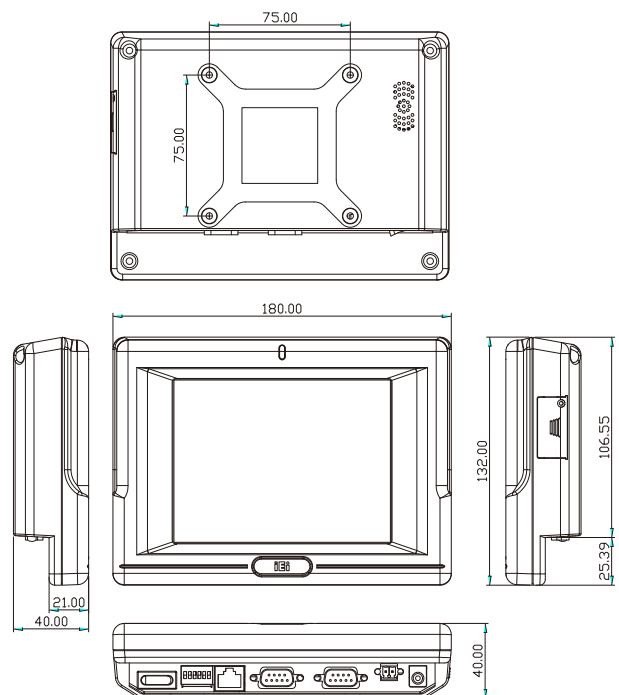

## Options

Part No.	Description
ALFPK-08	Panel mount kit
AFLWK-07	VESA 75 wall mount kit
ARM-11-RS	LCD Monitor/PPC Arm kit loading capacity from 3kg~7kg
STAND-A08-RS	LCD Monitor/PPC Stand kit for VESA 75 and support up to 5 Kg
VSTAND-A07	LCD Monitor/PPC STAND V type for VESA 75, 0~90 degree adjustable hinge and support up to 2.5 Kg
63000-PSP0601AD101CT60-RS	12V DC 60W power adapter with bare wire, 90~264V AC input